

This article was downloaded by:

On: 24 January 2011

Access details: *Access Details: Free Access*

Publisher *Taylor & Francis*

Informa Ltd Registered in England and Wales Registered Number: 1072954 Registered office: Mortimer House, 37-41 Mortimer Street, London W1T 3JH, UK



Journal of Macromolecular Science, Part A

Publication details, including instructions for authors and subscription information:

<http://www.informaworld.com/smpp/title~content=t713597274>

Batch Stripping of Vinyl Chloride

R. K. S. Chan^a; C. B. Patel^a; R. Gupta^a; C. H. Worman^a; R. E. Grandin^a

^a Plastics Technology Department Air Products & Chemicals Inc., Allentown, Pennsylvania

To cite this Article Chan, R. K. S. , Patel, C. B. , Gupta, R. , Worman, C. H. and Grandin, R. E.(1982) 'Batch Stripping of Vinyl Chloride', Journal of Macromolecular Science, Part A, 17: 7, 1045 – 1064

To link to this Article: DOI: 10.1080/00222338208066466

URL: <http://dx.doi.org/10.1080/00222338208066466>

PLEASE SCROLL DOWN FOR ARTICLE

Full terms and conditions of use: <http://www.informaworld.com/terms-and-conditions-of-access.pdf>

This article may be used for research, teaching and private study purposes. Any substantial or systematic reproduction, re-distribution, re-selling, loan or sub-licensing, systematic supply or distribution in any form to anyone is expressly forbidden.

The publisher does not give any warranty express or implied or make any representation that the contents will be complete or accurate or up to date. The accuracy of any instructions, formulae and drug doses should be independently verified with primary sources. The publisher shall not be liable for any loss, actions, claims, proceedings, demand or costs or damages whatsoever or howsoever caused arising directly or indirectly in connection with or arising out of the use of this material.

Batch Stripping of Vinyl Chloride

R. K. S. CHAN, C. B. PATEL, R. GUPTA, C. H. WORMAN, and
R. E. GRANDIN

Plastics Technology Department
Air Products & Chemicals, Inc.
Allentown, Pennsylvania 18105

ABSTRACT

A model simulating VCM batch stripping is proposed. It includes three modes of mass transfer: 1) from solid to vapor (nucleate boiling), 2) solid to liquid (both bulk diffusion and Knudsen diffusion), and 3) liquid to vapor (Fickian mass transfer). The involved partition and mass transfer coefficients have been measured to reduce the number of unknown parameters in the model equations. Devices were constructed to measure the three phase (solid/liquid/vapor) concentrations vs stripping time for parametric estimation and examination of model validity. It appears that the batch stripping data can be matched successfully. The model is used to study the mass transfer mechanism at different stages of the batch stripping cycle and the sensitivity of different parameters. In the beginning period, nucleate boiling was found to be comparable with the second mode (solid to liquid) mass transfer which prevails gradually in later stages of the cycle. The third mode (liquid to vapor) mass transfer appears to be of lower sensitivity. Such findings can be correlated with the effects from resin and equipment variables on stripping efficiency.

INTRODUCTION

Emission control of vinyl chloride (VCM) has been an important subject in the PVC industry because of the carcinogenicity of VCM [1-3]. Phenomenological modeling has been proposed in the literature [4-6] to simulate VCM removal. In all previous work, neither the nucleate boiling mass transfer nor equipment variables have been included in the models. It is intended to develop a mechanistic model to relate VCM concentrations in three phases (solid/liquid/vapor) as a function of time to the following groups of variables:

1. Material properties in terms of involved partition coefficients and mass transfer coefficients to characterize the mass transfer across solid/liquid, solid/vapor, and liquid/vapor phases.
2. Equipment variables such as evacuation capacity and stripping vessel size.
3. Operating conditions including temperature, % fillage of the stripping vessel, solid/water ratio, and initial VCM concentrations in three phases.

The model can then serve as a tool for design and process improvement purposes.

MODEL DEVELOPMENT

Assumptions of our model are as follows:

1. Because relatively short thermomechanical history is involved in regular commercial batch stripping, molecular relaxation [5], which is responsible for long-term change of diffusional characteristics, is neglected.
2. Because of the small size of particles involved, core/shell distribution of VCM concentration along the radial direction in the particle (Type II diffusion [7]) is neglected.
3. Both Type II and Knudsen diffusions can be combined and represented by regular Fickian diffusion via mass transfer coefficient approach with the assumption that the VCM concentration is uniform along the radial direction of the particles.

The model basically accounts for three modes of mass transfer occurring in regular commercial batch stripping processes:

1. From solid to vapor phase (nucleate boiling).
2. From solid to liquid (aqueous) phase (regular Fickian diffusion).
3. From liquid phase to vapor phase (regular Fickian diffusion).

Since nucleate boiling is only encountered in the devolatilization of low boiling monomers, it will be elaborated before the presentation of model equations.

Analogous to the mass transfer term for Fickian diffusion, it is the product of three terms, one mass transfer coefficient, one extensive parameter, and one driving force term [8, 9]. Let B be the VCM removal rate (mol/cc of PVC's) from nucleate boiling.

$$B = K_n C_s \Delta P_n \tag{1}$$

where K_n is the nucleate boiling mass transfer coefficient, C_s is the extensive property (similar to the area term for Fickian diffusion), and ΔP_n is the driving force term which can be expressed as follows (see the Symbols Section): Notations).

$$\Delta P_n = C_s H_{sv} - (P_m + hg\rho_{SL}) \tag{2}$$

where the slurry density

$$\rho_{SL} = (Q\rho_S + V_L\rho_L)/(V_L + Q) \tag{3}$$

When the product, $C_s H_{sv}$, exceeds the sum of VCM partial pressure and hydrostatic pressure from the water phase, the nucleate boiling driving force will exist (see Fig. 1) from $h = 0$ at the slurry

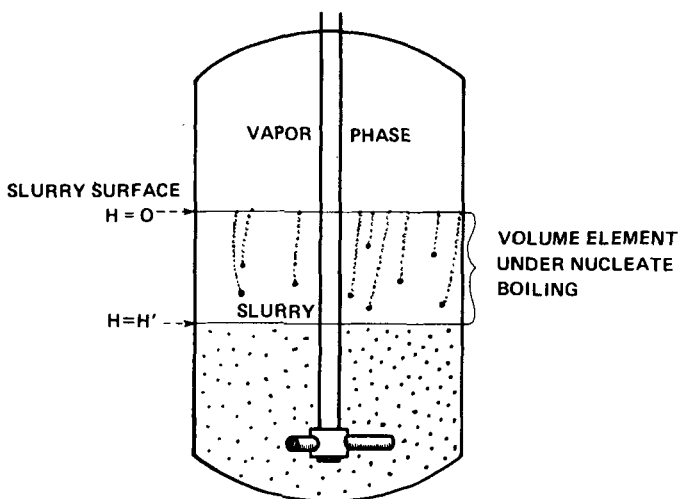

FIG. 1. Nucleate boiling of VCM in a batch stripper.

surface to $h = h'$ where $\Delta P_n = 0$. Namely, the PVC solid at the level of $h = h'$ in the vessel will not "boil" because of hydrostatic pressure. The stripping rate from nucleate boiling in the slurry element of volume, $\pi r^2 dh$, is

$$B = \left(\frac{\pi r^2 dh}{Q + V_L} \right) K_n C_s \Delta P_n \quad (4)$$

The total VCM stripping rate from nucleate boiling in the vessel is

$$\begin{aligned} B &= [(\pi r^2 K_n C_s / (Q + V_L))] \int_0^{h'} (C_s H_{SV} - (P_M + hg\rho_{SL})) dh \\ &= \frac{\pi r^2 K_n C_s}{2(Q + V_L)g\rho_{SL}} (C_s H_{SV} - P_m)^2 \end{aligned} \quad (5)$$

where

$$h' = (C_s H_{SV} - P_m) / g\rho_{SL} \quad (6)$$

When C_s decreases with time in a stripping cycle, h' also decreases and then diminishes with time.

The derivation of the following three model equations is given in Appendix 1:

$$-\frac{dC_s}{dt} = K_{SL}(C_s H_{SL} - C_L) + B \quad (7)$$

$$-\frac{dC_L}{dt} = \frac{K_{LV}(\pi r^2)}{V_L} \left(C_L - \frac{P - P_w}{H_{LV}} \right) - \frac{K_{SL}Q}{V_L} (C_s H_{SL} - C_L) \quad (8)$$

$$-\frac{dP}{dt} = \frac{RT}{(V_R - Q - V_L)} \left(B - \frac{G(P - P_w)}{P} + K_{LV}(\pi r^2) \left(C_L - \frac{P - P_w}{H_{LV}} \right) \right) \quad (9)$$

Because the state variables C_s , C_L , and P (vs time) are related to equipment variables (G , r , and V_R) and operating conditions (Q , V_L , and T) through too many material parameters (H_{SL} , H_{LV} , K_n , K_{SL} , and K_{LV}), reduction of the number of unknown parameters is necessary before parametric adjustment to fit actual stripping data of C_s , C_L , and P vs time. The next section summarizes the results of H_{SL} , H_{LV} , H_{SV} , and K_{SL} measured in our laboratory and delineates how we measure C_s , C_L , and P during stripping. Finally, the section on "simulation results" depicts the parametric estimation of K_n and K_{LV} based on the observed data of C_s , C_L , and P vs time, and compares the calculated results of C_s , C_L , and P with the observed data for model evaluation.

EXPERIMENTAL

Partition and Mass Transfer Coefficients

Because the transport properties of VCM depend on the partition and mass transfer coefficients, considerable efforts [10-16] have been devoted to their measurements. Such experiments require very sensitive detection as well as extremely careful handling of VCM, a very low boiling monomer.

The data generated from our laboratory using the internal and external samplers for partition coefficient [15] and fluid-flushing method for mass transfer coefficient measurements [16] are summarized as follows:

1. Both H_{SL} and H_{LV} of PVC in the range from 80 to 110° C can be represented as

$$\log H_{LV} = 13.68 - \frac{971.1}{T^{\circ}K} \tag{10}$$

$$\log H_{SL} = 0.03856 - 0.0002625(T^{\circ}K - 273) \tag{11}$$

2. The mass transfer coefficients, K_{SL} , of PVC vary with both temperature and VCM concentration. At 80° C K_{SL} for a kind of PVC exhibits the following relationship with C_s [16]:

$$\log K_{SL} \text{ (s}^{-1}\text{)} = -0.1827 + 0.5267 \log C_s \text{ (mol/cc)} \quad (12)$$

Devices for Obtaining Solid/Liquid/Vapor Samples during VCM Stripping Operation

The driving force terms of different modes of mass transfer in the modeling equations contain the partition coefficients and the VCM concentration in three phases under the dynamic conditions. The data of three-phase concentrations have to be measured reliably before they can be used to search for the unknown mass transfer coefficients K_n and K_{LV} , or to match the calculated data for model verification. Because of the volatility of VCM, the following criteria must be met in the design of the sampler:

1. Sampling must be rapid in order to obtain representative samples at that point in time during stripping.
2. Separation must be quickly obtained between liquid and solid phases before C_s and C_L drift toward equilibrium.
3. The size of the liquid and slurry samples must be large enough to insure that, upon dissolution, the quantity of residual monomer will be such that it can be reliably detected by gas chromatography. This factor is extremely important when analyzing liquid-phase samples at the end of the stripping cycle. It has been found that a 10 to 12 g liquid sample and a slurry sample of 6 to 8 g water plus resin, is usually sufficient in our operation.
4. The elimination of all dead volumes in the sampling device facilitates thorough flushing and cleaning after sampling operations.

Description of Slurry/Liquid Sampler

The basic piece of equipment used to sample the resin slurry during stripping is a three-way ball valve (I). In a single inlet and double outlet configuration (Fig. 2), the inlet side of the valve is attached directly to the stripping vessel through a stainless steel tubing extending into the vessel. A male run tee is attached to the horizontal outlet side of the three-way valve. Teflon inserts with an opening of the same dimension as the tee, valve, and fittings are inserted into the inlet and outlets of the three-way valve to eliminate dead space volume and to facilitate cleaning of the apparatus when flushed with water and nitrogen after sampling. A union tee is placed between the male run tee and the horizontal close-off ball valve (IV). The water sample is taken at the vertical position of the union tee. A fine mesh stainless steel screen, glass fiber filter, and a glass wool plug

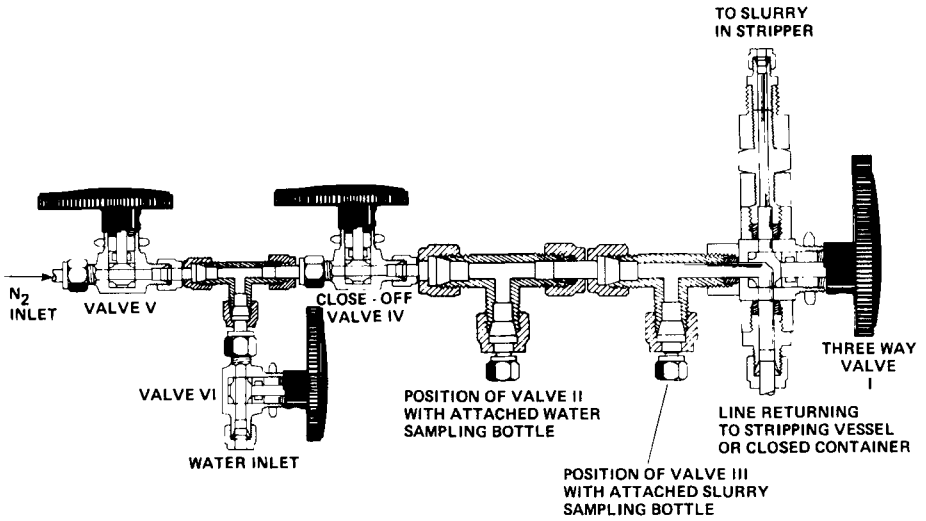

FIG. 2. "Slurry sampler" for liquid and solid phases.

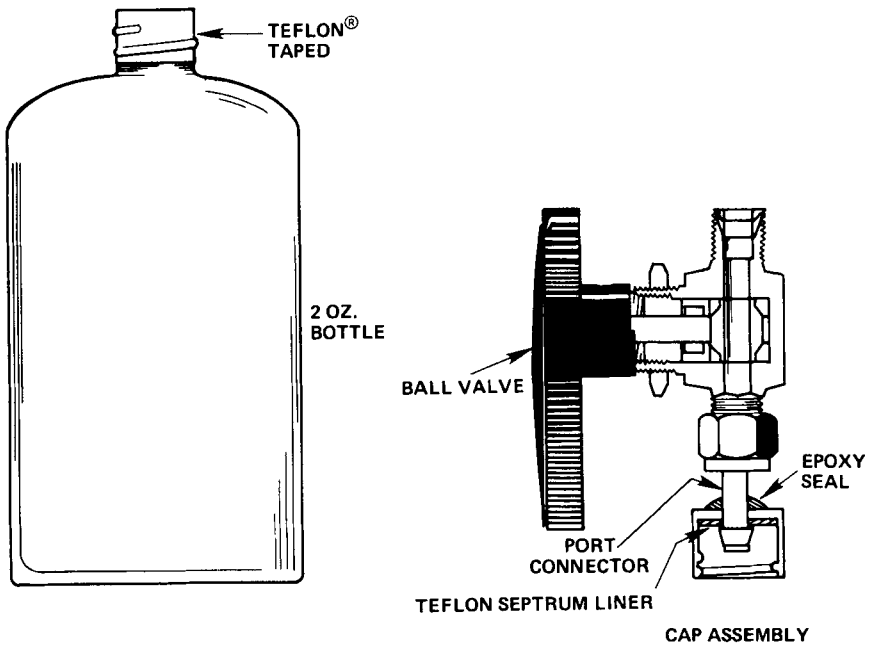

FIG. 3. Bottle and cap assembly for liquid and slurry samples.

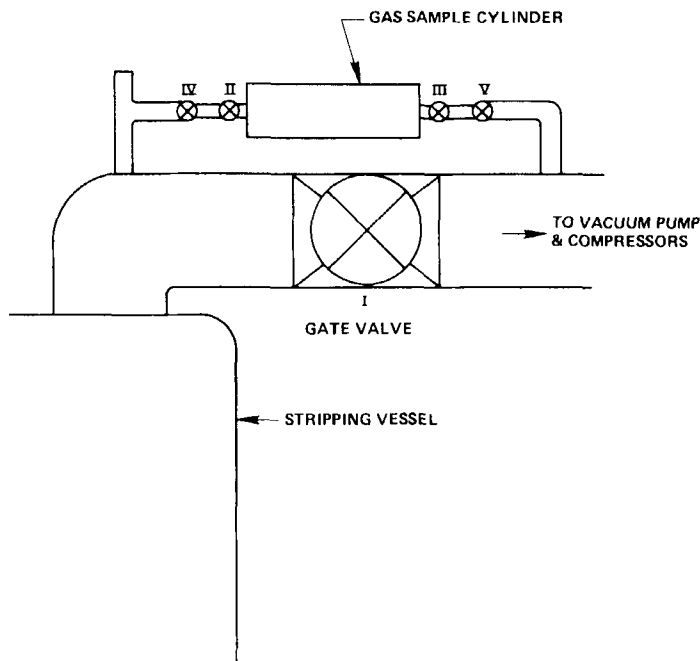

FIG. 4. Vapor sampling system.

are placed in the reducing port connector and attached to the vertical fitting of the union tee to enable the filtering of solid from the slurry sample. The glass wool plug is used to prevent lifting of the glass fiber filter by the suction action of the nitrogen used to clean the previous slurry sample in the line leading into the stripping vessel. A reducing port connector is attached to the vertical fitting of the male run tee so that the slurry sample may be directly taken at this position of the sampler. Sampling bottles for water and slurry are attached to the described positions (see Fig. 3). Ball valves that are adapted to the caps of 2 ounce glass sampling bottles present a leak-tight system by which slurry and water samples can be obtained without the loss of vinyl chloride monomer. Additional ball valves are placed in line with the main sampler itself, allowing use of nitrogen and water in the cleaning process. The slurry that remains in the sampler after use is flushed with water through the three-way ball valve. A fitting with a line leading back to the stripping vessel, or into a closed container, is attached to the vertical outlet of the three-way ball valve. The operating procedure of the slurry/liquid sampler is described in Section A of Appendix 2. The procedure for dilution of slurry/liquid samples by the THF for GC analysis of VCM is

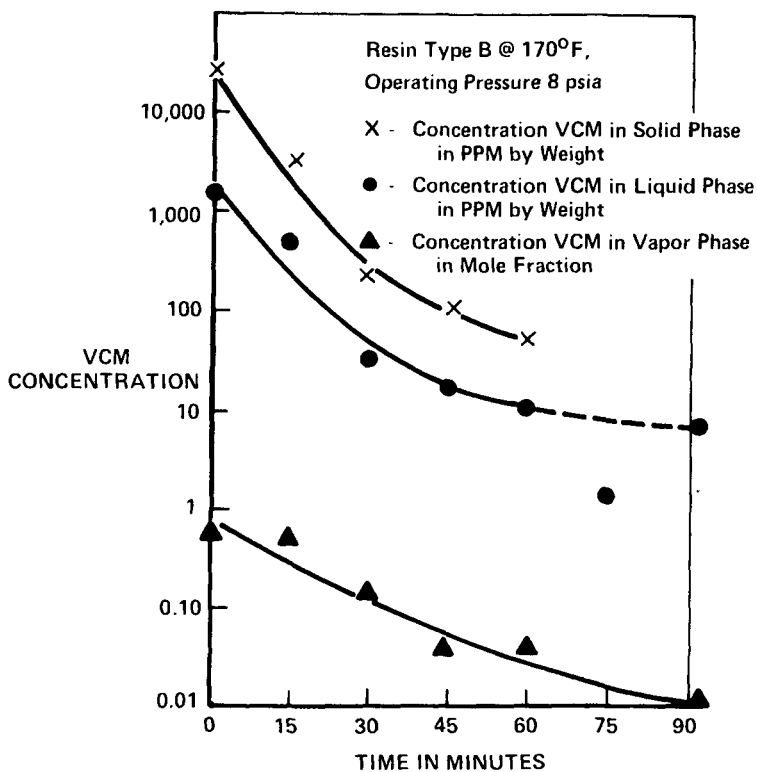

FIG. 5. VCM concentration in solid, liquid, and vapor phases as a function of time during plant stripping.

depicted in Section B of Appendix 2. The limit of detectability of our GC analysis via flame ionization detector is as little as 0.2 n of VCM.

Description of Gas Sampling Device

In order to obtain a complete profile of the VCM stripping operations, it is necessary to sample the vapor phase simultaneously with the slurry. The method used for obtaining the sample is to mount a gas sampling cylinder in a by-pass arrangement (see Fig. 4). This enables a representative sample to be taken under conditions of both pressure and vacuum. A gate valve is mounted in the main vacuum line. Close-off ball valves are used before and after the gate valve as a by-pass. These 1-in. lines and a vacuum header are insulated to prevent water vapor condensation. A 300-cc gas sampling cylinder

TABLE 1. Typical VCM Batch Stripping Data at 80°C^a

Time (h)	C _S (g·mol/cc)	C _L (g·mol/cc)	P (dyn/cm ²)
0	0.16 × 10 ⁻³	0.147 × 10 ⁻⁴	1.0 × 10 ⁶
0.4	0.127 × 10 ⁻⁴	0.4207 × 10 ⁻⁶	4.6 × 10 ⁵
0.82	0.299 × 10 ⁻⁵	0.1076 × 10 ⁻⁶	4.4 × 10 ⁵
1.26	0.151 × 10 ⁻⁵	0.908 × 10 ⁻⁷	4.4 × 10 ⁵
1.64	0.9863 × 10 ⁻⁶	0.703 × 10 ⁻⁷	4.5 × 10 ⁵

^aT = 353 K, P_W = 0.464 × 10⁶ (dyn/cm²), V_L = 0.823 × 10⁷ (cm³), Q = 0.286 × 10⁷ (cm³), V_R = 0.379 × 10⁸ (cm³), V = 0.183 × 10³ (cm), G = 7.8 (g·mol/s), H_{LV} = 0.876 × 10¹¹ (dyn·cm/mol), H_{SL} = 0.0176, H_{SV} = 0.252 × 10¹⁰ (dyn·cm/mol).

with attached ball valves is mounted in the by-pass line. The sampling procedure of the gas sampler is described in Section C of Appendix 2. It appears that the partial pressure of VCM from the gas sampler can be closely represented by (P - P_W^o) from pressure measurements, i.e., the contribution from inert gases is negligible in our batch stripping system.

Results From the Sampling Devices

Typical results obtained from the analysis of the VCM concentration solid, liquid, and vapor phases during a batch stripping operation are shown in Fig. 5. The results are plotted as the log of concentration of vinyl chloride in two (solid/liquid) phases and mole fraction of VCM in the vapor phase versus time. Table 1 shows their numerical values and conditions at which the data were taken.

Simulation Results and Validity of The Model

It was found that the solid concentration curve C_S vs time fits a variety of model equations. However, fitting C_S and C_L vs time requires more precise modeling. This was the principal reason for collecting data relating C_L and P_m vs time. When both C_S and C_L vs time curves are properly fitted, P_m vs time data will be automatically satisfied. Figures 6 and 7 show both the experimental data and

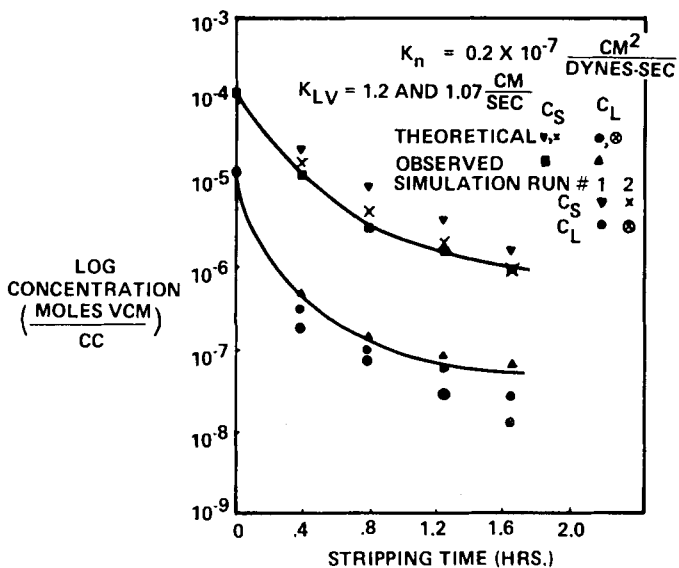

FIG. 6. Matching of experimental and theoretical results of concentrations vs stripping time (hydrostatic pressure considered).

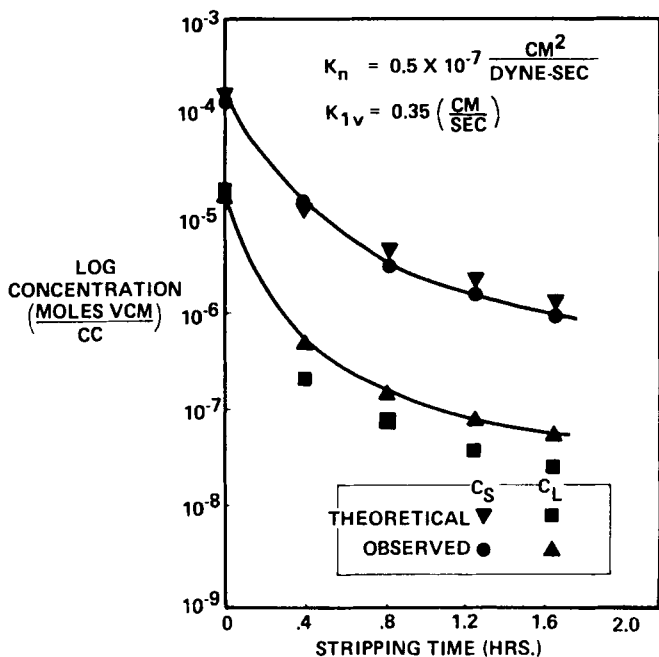

FIG. 7. Matching of experimental and theoretical data of concentrations vs stripping time (hydrostatic pressure neglected).

TABLE 2. Rate Constants in VCM Batch Stripping at 80°C (C_s from 50,000 to 100 ppm)

Symbol	Mode of mass transfer	Fitted values, Case A ^a	Fitted values, Case B ^b	Dimension
K_N	Nucleate boiling from solid phase	0.2×10^{-7}	0.5×10^{-7}	$\text{cm}^2/\text{dyn}\cdot\text{s}$
K_{SL}	Regular mass transfer from solid to liquid	Eq. (1)	Eq. (1)	s^{-1}
K_{LV}	Regular mass transfer from liquid to vapor phase	1.2	0.35	cm/s

^aHydrostatic pressure considered.

^bHydrostatic pressure not considered.

theoretical curves based on with and without considering the hydrostatic pressure effect on nucleate boiling. The corresponding sets of K_N and K_{LV} are listed in Table 2. The value of K_{LV} is approximately one order of magnitude higher than the literature value [17]. This is possibly due to surface turbulence from agitation which greatly amplifies the mass transfer area across the liquid/vapor interface. It is difficult to compare K_n with the literature because nucleation phenomenon is involved. The close matching qualifies the validity of the model. By comparing the two terms on the right-hand side of Eq. (7), it was found that at 80°C the mass transfer from nucleate boiling is higher but comparable with that of the second mode (solid to liquid) in the beginning of a batch stripping cycle. The second mode of mass transfer prevails at the end of the cycle while nucleate boiling diminishes. The third mode of liquid-to-vapor mass transfer is of lower sensitivity. Figures 8 to 11 show the sensitivity of the mass transfer coefficients and evacuation capacity on stripping rate under the same conditions except K_{SL} was assumed to be independent of concentration C_s in contrast to Eq. (12).

Sometimes a negative driving force of the mass transfer from solid to liquid in the beginning period of some batch stripping cycles was observed. This is possible only when rigorous nucleate boiling is occurring and creates an oversaturated VCM concentration in the liquid phase. The occasional coexistence of the positive driving force for nucleate boiling and negative driving force for Fickian diffusion from solid was indeed experienced in our calculations.

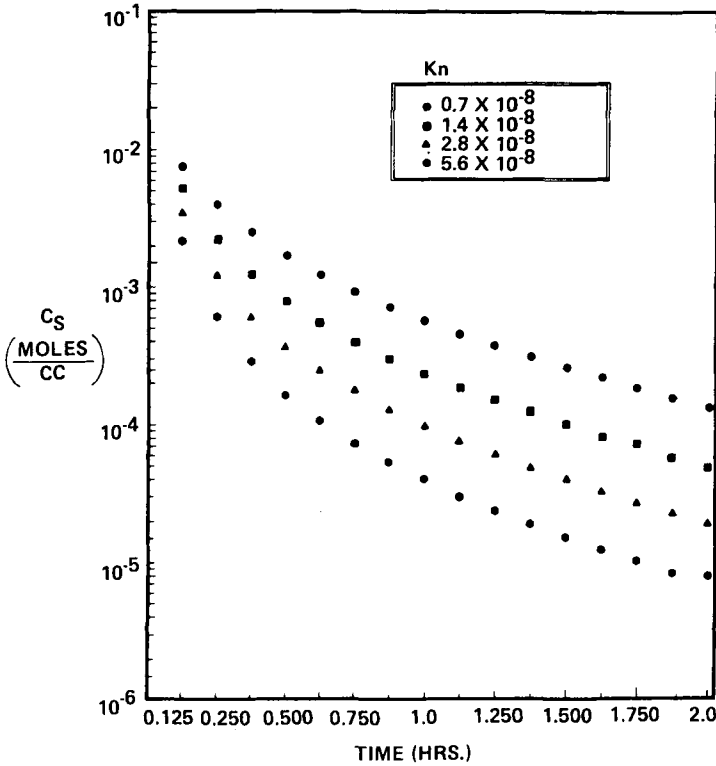

FIG. 8. The effect of varying K_n on VCM removal rate at 80°C.

SUMMARY AND CONCLUSIONS

A model simulating the batch stripping of vinyl chloride or highly volatile monomers was proposed to account for three modes of mass transfer:

1. Nucleate boiling from solid to vapor phase.
2. Fickian diffusion from solid to liquid phase.
3. Fickian diffusion from liquid to vapor phase.

Also, the model equations include material properties and equipment variables as well as operating conditions.

Samplers were devised to measure the concentration of VCM in three phases (solid/liquid/vapor) during batch stripping.

After the parameters from material properties have been experimentally measured or theoretically estimated, the predicted values

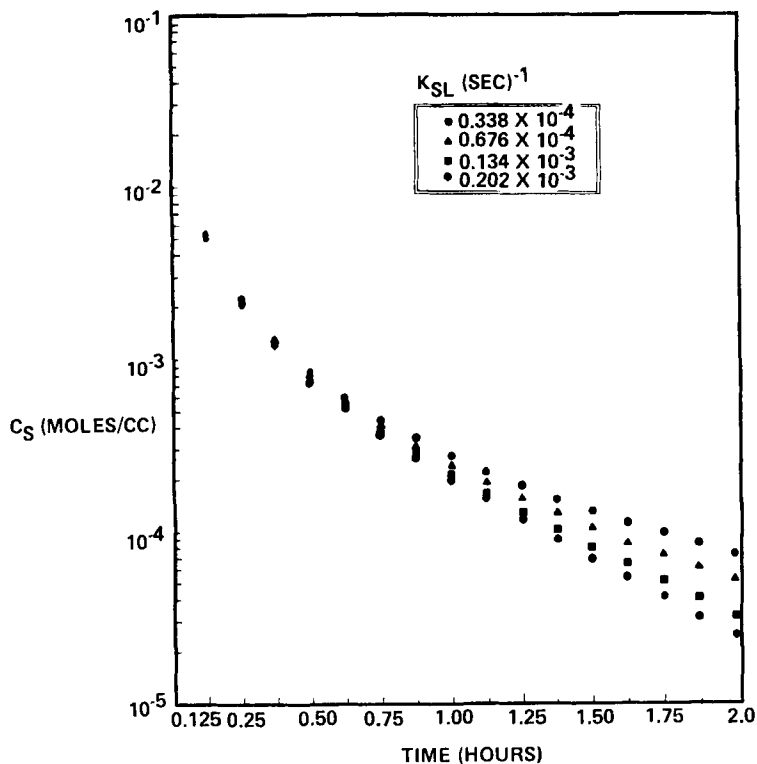

FIG. 9. Effect of varying K_{SL} on VCM stripping rate of PVC slurry at 80°C .

of VCM concentration in three phases were compared with the observed values. The close match between experimental and theoretical results validates the concepts of the model.

The model equations can be used for parametric estimation, comparison of the relative importance of various modes of mass transfer, and sensitivity studies.

It was found that in the beginning of the batch stripping cycle, the mass transfer from nucleate boiling is comparable with that from solid to liquid, which presides gradually in later stages of the cycle. The third mode of (liquid/vapor) mass transfer appears to be of lower sensitivity.

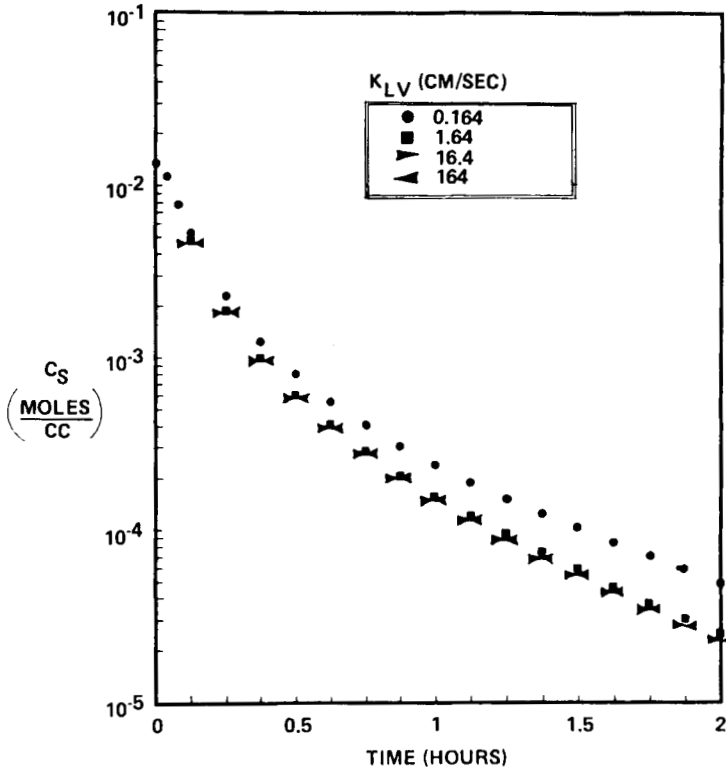

FIG. 10. Effect of varying K_{LV} on VCM stripping rate of PVC slurry at 80°C.

APPENDIX 1. DERIVATION OF MODEL EQUATIONS

The state variables are C_s , C_L , and P . Their rate of change is equal to the sum of incoming and outgoing fluxes. For example:

$$-\frac{dC_s}{dt} = K_{SL}(C_s H_{SL} - C_L) + B \tag{7}$$

The decreasing rate of C_s is equal to the sum of two outgoing terms, one from the regular Fickian mass transfer and the other from nucleate boiling. The parenthetical term $(C_s H_{SL} - C_L)$ represents

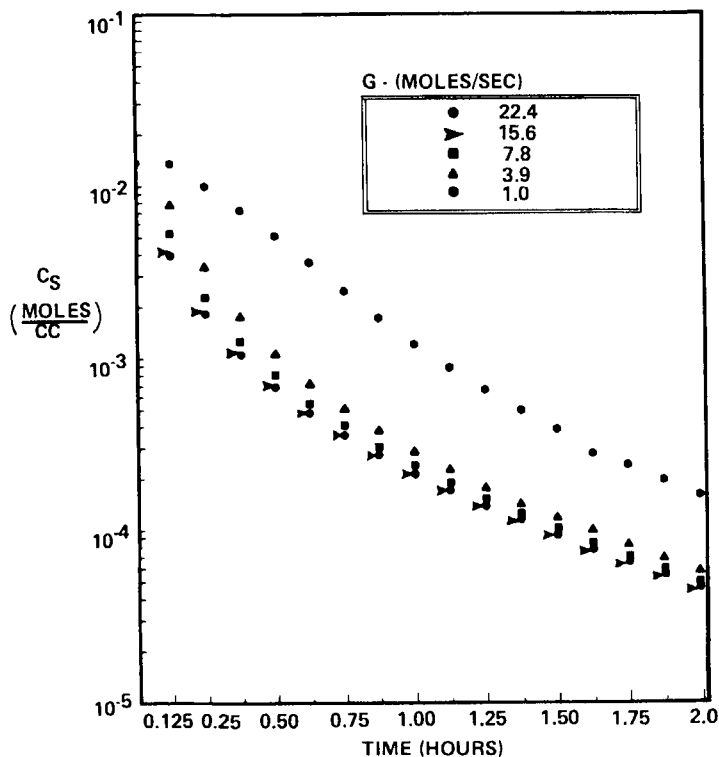

FIG. 11. Effect of varying evacuation capacity on VCM stripping rate of PVC slurry at 80°C.

the driving force for the Fickian mass transfer and the overall mass transfer coefficient

$$\begin{aligned}
 K_{SL} &= K_{SL}' A_{SL} / Q \\
 &= 6K_{SL}' / \phi
 \end{aligned}
 \tag{13}$$

In other words, the overall solid/liquid mass transfer coefficient, K_{SL} , is equal to six times the regular Fickian mass transfer coefficient divided by the effective diameter of the particles for diffusion.

Similarly, Eq. (8) has on the right-hand side an outgoing term from liquid/vapor mass transfer and an incoming term from solid/liquid mass transfer. The former includes the mass transfer coefficient

(K_{LV}), the nominal vapor/liquid interfacial area (r^2), and the driving force, $(C_L - P_m/H_{LV})$.
 Since

$$P_m = P - P_W^\circ \quad (14)$$

P_m will be replaced by $P - P_W^\circ$ in Eqs. (8) and (9) because P is a measurable state variable. Equation (9) has three terms on the right comprising the mass transfer from solid to liquid, nucleate boiling, and evacuation, $G(P - P_W)/P$. The terms V_L in Eq. (8) and $RT/(V_R - Q - V_L)$ in Eq. (9) are included for dimensional balance.

APPENDIX 2

A. Sampling Procedure of the Slurry Liquid Sampler

1. With the valve I handle turned in the horizontal position, the evacuated 2-ounce glass bottles with Valves II and III in the closed position are attached to the sampler.
2. To obtain a sample, make sure that Valves II, III, and IV are in the closed position with an approximately 80 psig nitrogen source attached to Valve V. Open Valves IV and V, and turn the main Valve I to inlet configuration (pointer of handle is upward). Nitrogen is purged through the system to sweep out any remaining slurry in the line into the stripping vessel.
3. Turn off Valves IV and V, and slowly crack Valve II to obtain the desired amount of water sample, approximately 10 to 12 g. (Evacuated bottles are critical to initiate flow through the system.)
4. Close Valve II and slowly crack Valve III to obtain the desired amount of slurry in the bottle, approximately 6 to 8 g total water and solids. (Evacuated bottles are critical to initiate flow through the system.)
5. Close Valve III and turn the handle of the main Valve I by 180° . This will close off the sample line to the stripping vessel and relieve pressure in the sampler setup.
6. Open Valves VI and IV to allow water to be flushed through the system. This will rinse the slurry and VCM vapor through the line attached to the vertical position of the valve. This line can lead back to the stripping vessel or to a closed container.
7. After rinsing, Valve I is returned to the horizontal position and sample bottles with Valves II and III are removed from the sampler.

8. Remove the fitting container filter and flush the apparatus with water.
9. Close off water Valve VI and purge with nitrogen until the sampler is dry. Then close Valves IV and V and place a fresh filter back on the apparatus. The equipment is now ready for the next sample.

B. Sample Preparation Prior to VCM Analysis of Water and Slurry Samples

Bottles that are used to contain the samples are tare weighed with the valves attached. It was found that a leak-tight system could be obtained by wrapping bottle threads with Teflon pipe sealing tape. A tare weight is also obtained on the same bottle with an aluminum foil-lined cap. After samples have been obtained from the stripping operation, the weights of water and slurry are obtained.

Sample bottles are then connected to a pressurized vessel containing chromatographically pure THF. THF, pressurized with nitrogen, is used to fill the sample bottles. This filling method prevents the loss of VCM vapor. The valves on the sample bottles are then removed and the foil-lined caps are placed on the bottles which are reweighed to determine the amount of THF added. After complete dissolution, the samples are ready for analysis of VCM concentration by gas chromatography. After determination has been made of the VCM content in the water and the slurry, the polymer solution is placed in a tared aluminum dish and the solvent is evaporated to obtain the total weight of resin in the slurry. From the previous weights an accurate concentration of VCM in the solid phase can be determined by correcting for the amount of VCM in the water phase of the slurry at the time of sampling.

C. Sampling Procedure of the Gas Sampling Device

1. Cylinder should be completely leak checked before operations.
2. Ball Valves II, III, IV, and V are opened.
3. The gate valve is slowly closed to reduce flow through the main vacuum line until flow is detected in the 1 in. line and the sample cylinder. This can be indicated by installing a flowmeter in the 1 in. line or by noticeable heating of the gas sampling cylinder.
4. After vapor has purged through the cylinder for a short period of time, Valves II and III are closed simultaneously and then Valves IV and V are closed. This procedure ensures that no VCM is released from the connecting lines upon disconnection of the equipment. The gate valve is slowly opened to resume normal flow.

5. The gas sampling cylinder is removed and immediately taken to the laboratory for analysis.

SYMBOLS

C	concentration (g·mol/cc)
P	total pressure (dyn/cm ²), the sum of partial pressures = P _m + P _w
T	temperature (°K)
R	gas constant = (dyn·cm/mol°K)
r	reactor radius (cm)
V	volume (cc)
Q	charged polymer (PVC) volume (cc)
G	evacuation capacity of vacuum pump (g·mol/cc)
φ	effective particle diameter for Fickian diffusion (cm)
H	partition coefficient
H _{LV}	partition coefficient of VCM in liquid and vapor phases in (dyn·cm/mol)
H _{SL}	partition coefficient of VCM in solid (PVC) and liquid phases, in (mol/cc)/(mol/cc)
H _{SV}	partition coefficient of VCM in solid and vapor phases in dyn·cm/mol
K	mass transfer coefficients from one phase denoted by the first subscript to another denoted by the second subscript
K _{SL}	mass transfer coefficient from solid to liquid (cm/s)
K _{LV}	mass transfer coefficient from liquid to vapor phase (cm/s)
K _{SL}	6K _{SL} '/φ (s ⁻¹)
K _n	nucleate boiling coefficient in cm ² /dyn·s
A _{SL}	solid/liquid interfacial area of the effective particles (cm ²)
B	VCM stripping rate from nucleate boiling (mol/cc of PVC·s)

Subscripts

S	solid phase; in this work, PVC
L	liquid phase; in this work, water
V	vapor phase, assumed to be VCM and water vapor only

R	reactor
N	nucleate boiling
M	monomer; in this work, VCM
W	water
SL	slurry = solid and liquid phases

ACKNOWLEDGMENTS

The authors are in debt to Drs G. J. Mantell, M. Langsam, and N. Friis for reviewing and proofreading the manuscripts. They also wish to thank Drs G. T. Fox and K. Anselmo for their assistance in computation, and finally Air Products & Chemicals, Inc., for their generosity of releasing the paper for outside presentation.

REFERENCES

- [1] Federal Register, **39**, 194 (1975).
- [2] Federal Register, **40**, 248 (1975).
- [3] Federal Register, **40**, 71 (1975).
- [4] J. F. Scamehorn and K. Yang, Proceeding, AIChE 70th Annual Meeting, New York, November 1977.
- [5] A. R. Berens and H. B. Hopfenberg, J. Polym. Sci., Polym. Phys. Ed., 17, 1757 (1979).
- [6] G. J. Mantell, J. T. Barr, and R. K. S. Chan, Chem. Eng. Prog., 71, 54 (1975).
- [7] A. Peterlin, J. Polym. Sci., Polym. Phys. Ed., 17, 1741 (1979).
- [8] M. Volmer, "Kinetik der Phasenbildung," in Die Chemische Reaktion, Vol. 4 K. F. Bonhoeffer, ed.), Steinkopf, Leipzig, 1939.
- [9] L. S. Tong, Boiling Heat Transfer and Two Phase Flow, Wiley, New York, 1967.
- [10] A. R. Berens, Polym. Prepr., 15(2), 203 (1975); Polymer, 18, 697 (1977); Polym. Eng. Sci., 18(11), 864 (1978).
- [11] J. R. Morano, PhD Thesis, Rutgers University, 1975; J. F. Scamehorn and K. Yang, Polym. Eng. Sci., 18(11), 841 (1978).
- [12] T. Oishi and J. M. Prausnitz, Ind. Eng. Chem., Fundam., 17(2), 109 (1978).
- [13] A. H. Abdel-Alim, J. Appl. Polym. Sci., 22, 3597 (1978).
- [14] D. W. Brown and R. E. Lowry, J. Polym. Sci., Polym. Chem. Ed., 15, 2623 (1979).
- [15] C. B. Patel, R. E. Gradin, R. Gupta, E. M. Phillips, C. E. Reynolds, and R. K. S. Chan, Polym. J. (Jpn.), 11(1), 43, (1979).
- [16] C. B. Patel, R. Houck, R. Gupta, and R. K. S. Chan, J. Polymer Sci., Chem. Notes, 17, 3775 (1979).
- [17] P. L. T. Brian, H. B. Hales, and T. K. Sherwood, AIChE J., 15(5), 727 (1969).